

Zylinder ISO 15552 Serie 63

Neue Versionen

Alu-Profil/-Rundrohr, einfach-/doppeltwirkend,
Magnetversion, Endlagendämpfung, zahlreiche Versionen
Ø 32, 40, 50, 63, 80, 100, 125 mm



Die Zylinder der Serie 63 nach ISO 15552 vereinen hohe Leistungsfähigkeit mit universellen Einsatzmöglichkeiten. Sie verfügen über ein neues System einstellbarer Endlagendämpfungen und erzielen so eine feine Einstellmöglichkeit sowie eine signifikante Geräuschreduzierung beim Erreichen der Endlage.

Zusätzlich zur Standardversion mit Einsatzmöglichkeiten in den unterschiedlichsten Branchen wurden Versionen für spezifische Anwendungen in der Lebensmittelindustrie, Landwirtschaft, für Tänzerwalzen-Steuerungen oder Dosiersysteme entwickelt. Weitere Versionen sind für den Einsatz in anspruchsvollen Umgebungen mit hohen Anforderungen in Bezug auf Temperaturen, Korrosion oder Sicherheit geeignet.

- » ISO 15552 konform
- » Gewichtsreduziert um 25 %
- » Geräuscharm
- » Fein einstellbare Endlagendämpfung
- » Universell einsetzbar

VERSIONEN:

- » Leichtlauf
- » Gleichlauf
- » Hoch-/Tieftemperatur
- » Korrosionsbeständig
- » Hydrolysebeständig
- » Lebensmittelkonform
- » Ohne Schmierung
- » Verschmutzte und staubige Umgebungen
- » Kolbenstange mit Faltenbalg
- » Boden/Boden-Montage
- » Tandem- und Mehrstellversion
- » mit Feststelleinheit
- » PU-Beschichtung
- » ATEX zertifiziert

ALLGEMEINE KENNGRÖSSEN

| | |
|----------------------------|--|
| Bauart | Alu-Profil/-Rundrohr mit Zugankern |
| Norm | ISO 15552 |
| Funktion | Einfach-, doppeltwirkend |
| Befestigungsart | Fußbefestigung, Schwenkgabel vorn/hinten, Schwenklager sphärisch, Mittelschwenklager |
| Hub min - max | 10 ÷ 2500 mm |
| Umgebungstemperatur | Standard-, Leichtlaufversion: 0°C ÷ 80°C (mit getrockneter Luft bis -20°C) Hochtemperaturversion (Version W): 0°C ÷ 150°C (mit getrockneter Luft bis -20°C) Tieftemperaturversion (Version Z): -40°C ÷ 60°C Tieftemperaturversion (Version Y): -50°C ÷ 60°C |
| Lagertemperatur | 0°C ÷ 80°C (mit getrockneter Luft bis -20°C) |
| Betriebsdruck | 1 ÷ 10 bar (Standard, Tief- und Hochtemperatur) 0,1 ÷ 10 bar (Leichtlaufversion) |
| Geschwindigkeit | 10 ÷ 1000 mm/sec, ohne Last (Standard, Hoch- und Tieftemperatur) 5 ÷ 1000 mm/sec, ohne Last (Leichtlaufversion) |
| Medium | Gefilterte Luft Klasse 7.8.4, gemäß ISO 8573-1. Im Falle von geölter Luft empfehlen wir die Verwendung von Öl ISO VG 32 und die Schmierung nie zu unterbrechen. |
| Schaltelemente | 63MP: Mod. CSH, 63MT: Mod. CSH/CST + Mod. S-CST... |

STANDARDHÜBE ZYLINDER SERIE 63

■ = einfachwirkend, Feder vorn (Standard, Hoch temperatur Version); ▲ = einfachwirkend, Feder hinten (Standard, Hoch temperatur);
 ✕ = doppeltwirkend (Standard-, Leichtlauf-, Hoch-/Tieftemperaturversion); auf Anfrage Hübe bis max. 2500 mm

| STANDARDHÜBE | | 25 | 50 | 75 | 80 | 100 | 125 | 150 | 160 | 200 | 250 | 300 | 320 | 400 | 500 |
|--------------|-------|-------|-----|----|----|-----|-----|-----|-----|-----|-----|-----|-----|-----|-----|
| Ø | | | | | | | | | | | | | | | |
| 32 | ■ ▲ ✕ | ■ ▲ ✕ | ■ ✕ | ✕ | ✕ | ✕ | ✕ | ✕ | ✕ | ✕ | ✕ | ✕ | ✕ | ✕ | ✕ |
| 40 | ■ ▲ ✕ | ■ ▲ ✕ | ■ ✕ | ✕ | ✕ | ✕ | ✕ | ✕ | ✕ | ✕ | ✕ | ✕ | ✕ | ✕ | ✕ |
| 50 | ■ ▲ ✕ | ■ ▲ ✕ | ■ ✕ | ✕ | ✕ | ✕ | ✕ | ✕ | ✕ | ✕ | ✕ | ✕ | ✕ | ✕ | ✕ |
| 63 | ■ ▲ ✕ | ■ ▲ ✕ | ■ ✕ | ✕ | ✕ | ✕ | ✕ | ✕ | ✕ | ✕ | ✕ | ✕ | ✕ | ✕ | ✕ |
| 80 | ■ ▲ ✕ | ■ ▲ ✕ | ■ ✕ | ✕ | ✕ | ✕ | ✕ | ✕ | ✕ | ✕ | ✕ | ✕ | ✕ | ✕ | ✕ |
| 100 | | ■ ▲ ✕ | ■ ✕ | ✕ | ✕ | ✕ | ✕ | ✕ | ✕ | ✕ | ✕ | ✕ | ✕ | ✕ | ✕ |
| 125 | | ■ ▲ ✕ | ■ ✕ | ✕ | ✕ | ✕ | ✕ | ✕ | ✕ | ✕ | ✕ | ✕ | ✕ | ✕ | ✕ |

MODELLBEZEICHNUNG

| | | | | | | | | | | | | | | | |
|-----------|----------|----------|----------|----------|------------|----------|-------------|----------|--|--|--|--|--|--|--|
| 63 | M | P | 2 | C | 050 | A | 0200 | W | | | | | | | |
|-----------|----------|----------|----------|----------|------------|----------|-------------|----------|--|--|--|--|--|--|--|

| | | |
|-------------|--|---|
| 63 | SERIE | |
| M | BAUREIHE M = Standard, Magnetversion L = Leichtlaufversion, magnetisch | |
| P | BAUART T = Rundrohr P = Profilrohr | |
| 2 | BETRIEBSART 1 = Einfachwirkend, Feder vorn 2 = Doppeltwirkend 6 = Doppeltwirkend, durchgehende Kolbenstange 7 = Einfachwirkend, durchgehende Kolbenstange 9 = Einfachwirkend, Feder hinten | PNEUMATIKSYMBOLE CS07/CS18 CD08 - CD09 - CD10 - CD11 CD13 CS11 CS14/CS17 |
| C | ENDLAGENDÄMPFUNG N = Nicht gedämpft C = Beidseitig gedämpft F = Vorne gedämpft R = Hinten gedämpft | PNEUMATIKSYMBOLE CD08 CD09/CD13 CD11 CD10 |
| 050 | KOLBENDURCHMESSER 032 = 32 mm 040 = 40 mm 050 = 50 mm 063 = 63 mm | 080 = 80 mm 100 = 100 mm 125 = 125 mm |
| A | BEFESTIGUNGSART A = Standard, montiert mit Kolbenstangenmutter U RL = Zylinder mit Feststelleinheit | DC = Boden/Boden-Montage mit Mod. DC-63...[X1/X2] TR = Boden/Boden-Montage für Rundrohr [X1/X2] F = Zylinder mit Mittelschwenklager (nur bei Rundrohr) |
| 0200 | HÜBE = Standard N = Tandem / = Mehrstellung X1/X2 [X1 < X2] | |
| W | TEMPERATURBEREICHE = Standard W = Hochtemperaturversion (150°C) | Z = Tieftemperaturversion (-40°C) Y = Tieftemperaturversion (-50°C) |
| | KORROSIONSBESTÄNDIGKEIT = Standard C1 = Kolbenstangenmutter, Kolbenstange Edelstahl 1.4301 C2 = Kopschrauben oberflächenveredelt (Profil), Zugstangenmutter 1.4305, Zuganker 1.4028 (Rundrohr) | C3 = C2 + Kolbenstange/Mutter 1.4401 C4 = C1 + C2 C5 = C3 + Zylinderkopf mit 3-fach Schutz |
| | VERSIONEN = Standard (Kolbenstange mit Außengewinde) F = Kolbenstange mit Innengewinde K = Kopf/Deckel Kanigen-Beschichtung L = Ohne Kolbenstangendichtung (nur ausfahrend) V = Kolbenstangendichtung in FKM R = Kolbenstangendichtung in NBR U = Ohne Schmierung | H = Hydrolyse-Beständigkeit A = Für Einsatz mit Hygiene-/Sterilisations-Fluiden G = Trockene und staubige Umgebungen (Abstreifer in Messing, Kolbenstange 1.4028 verchromt) B = Kolbenstange mit Faltenbalg / NBR B2 = Durchgehende Kolbenstange mit beidseitigem Faltenbalg / NBR () = Kolbenstange verlängert um ___ mm |
| | SONSTIGES P = PU lackiert RAL 7035 | |
| | ZERTIFIZIERUNGEN EX = ATEX | |

ZYLINDER ISO 15552 SERIE 63

PNEUMATIKSYMBOLS

Pneumatiksymbole entsprechend der Modellbezeichnung.

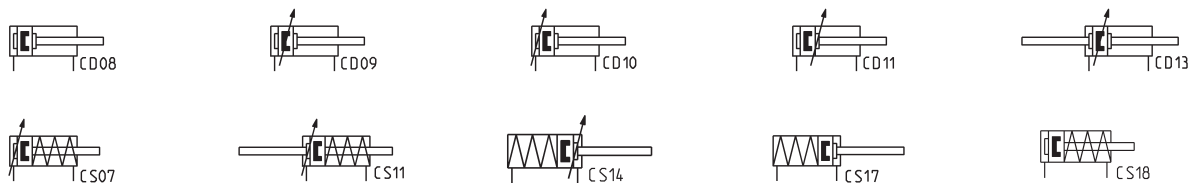

ZYLINDER ISO 15552 SERIE 63

BESCHREIBUNG DER BAUTEILE

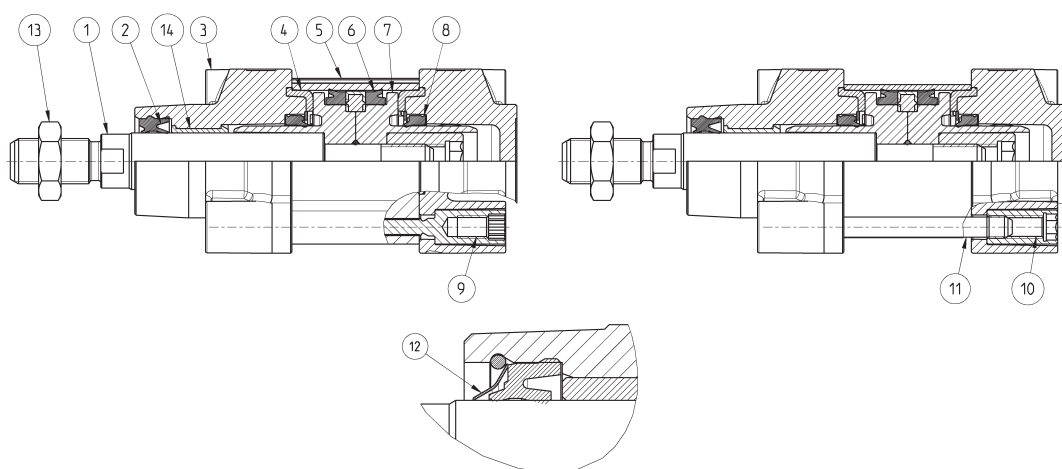

| BESCHREIBUNG DER BAUTEILE | | | | | | | |
|----------------------------------|---|--|----------------------------|--------------------------------------|--------------------------------------|----------------------------|----------------------------|
| BAUTEILE | Standard, Profilrohr | Standard, Rundrohr | Leichtlauf (L) | Abstreifer (G) | Tieftemperatur (Z/Y) | Hochtemperatur (W) | Korrosionsbeständig (C1) |
| 1 - Kolbenstange | Edelstahl Werkstoff 1.4028 | Edelstahl Werkstoff 1.4028 | Edelstahl Werkstoff 1.4028 | Edelstahl Werkstoff 1.4028 verchromt | Edelstahl Werkstoff 1.4028 verchromt | Edelstahl Werkstoff 1.4028 | Edelstahl Werkstoff 1.4301 |
| 2 - Kolbenstangendichtung | PU | PU | NBR | NBR | PU für -40°C / -50°C | FKM | PU |
| 3 - Deckel | Aluminium | Aluminium | Aluminium | Aluminium | Aluminium | Aluminium | Aluminium |
| 4 - Anschlagdichtung | NBR | NBR | NBR | NBR | NBR für -40°C / -50°C | FKM | NBR |
| 5 - Strangprofil | Aluminium eloxiert | Aluminium eloxiert | Aluminium eloxiert | Aluminium eloxiert | Aluminium eloxiert | Aluminium eloxiert | Aluminium eloxiert |
| 6 - Kolbendichtung | PU | PU | NBR | PU | PU für -40°C / -50°C | FKM | PU |
| 7 - Kolben | Kunststoff (ø 32 mm) oder Aluminium (ø 40 ÷ 125 mm) | Aluminium (ø 125 mm) oder Kunststoff (ø 32 ÷ 100 mm) | Aluminium | Aluminium | Aluminium | Aluminium | Aluminium |
| 8 - Endlagendämpfungsichtung | PU | PU | PU | PU | PU | FKM | PU |
| 9 - Zugankerschraube | Stahl verzinkt | - | Stahl verzinkt | Stahl verzinkt | Stahl verzinkt | Stahl verzinkt | Stahl verzinkt |
| 10 - Zugankermutter | - | Stahl verzinkt | Stahl verzinkt | Stahl verzinkt | Edelstahl Werkstoff 1.4305 | Stahl verzinkt | Stahl verzinkt |
| 11 - Zuganker | - | Stahl verzinkt | Stahl verzinkt | Stahl verzinkt | Edelstahl Werkstoff 1.4028 | Stahl verzinkt | Stahl verzinkt |
| 12 - Abstreifer | - | - | - | Messing | Messing | - | - |
| 13 - Kolbenstangenmutter | Stahl verzinkt | Stahl verzinkt | Stahl verzinkt | Stahl verzinkt | Edelstahl Werkstoff 1.4305 | Stahl verzinkt | Edelstahl Werkstoff 1.4301 |
| 14 - Kolbenstangenführungsbuchse | Kunststoff | Kunststoff | Kunststoff | Kunststoff | Kunststoff | Stahl+PTFE | Kunststoff |

Modell- und Maßänderungen vorbehalten. Unsere AGBs finden Sie auf www.camozzi.de.

Zylinder Serie 63 Leichtlaufversion - Anwendungsbeispiele

ZYLINDER ISO 15552 SERIE 63

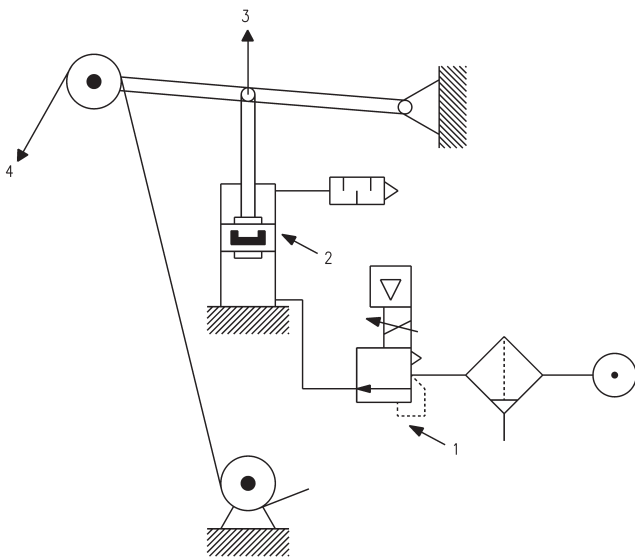

ZYLINDER AUSFAHREND

1. Präzisionsregler / Proportionalregler
2. Leichtlaufzylinder
3. Kraftrichtung
4. Seil/Band/Zahnriemen etc.

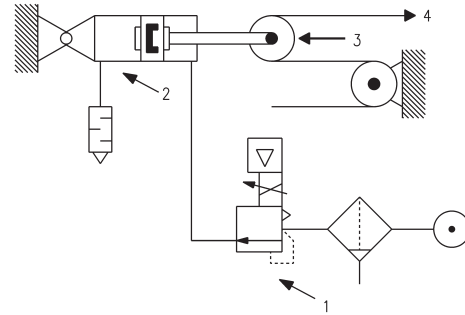

ZYLINDER EINFAHREND

Um optimalen Leichtlauf zu erreichen, empfiehlt sich der Einsatz eines Präzisionsdruckreglers oder eines Proportionalreglers (siehe Skizze).

SERIE 63 - ZUBEHÖR



Ausgleichskupplung
Mod. GY



Kolbenstangenmutter
Mod. U



Lagerbolzen Mod. S

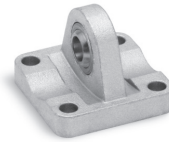

Schwenklager sphärisch
Mod. R

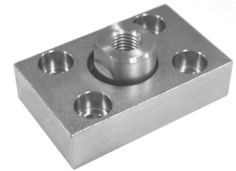

Ausgleichsflansch
Mod. GKF



Gelenkauge Mod. GA

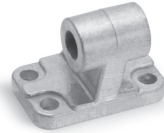

Lagerbock 90° mit starrem
Lager Mod. ZC

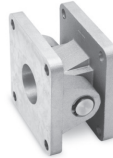

Kombination Mod. C, L, S

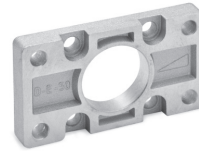

Flansch vorn und hinten
Mod. D-E



Ausgleichskupplung
Mod. GK



Mittelschwenklager
Mod. F-63



Fußbefestigung
Mod. B-41

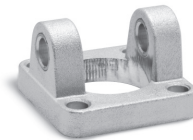

Schwenkgabel vorne
Mod. H und C-H

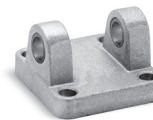

Schwenkgabel hinten
Mod. C und C-H

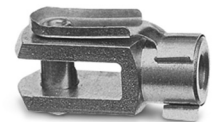

Gabelkopf Mod. G

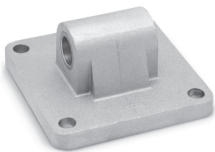

Schwenklager hinten
Mod. L



Demontagewerkzeug f.
Zylinder Ø 80 +100mm



Lagerbock Mod. BF



Mittelschwenklager vorne
Mod. FN

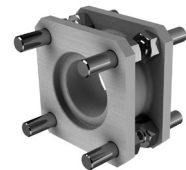

Mehrstellungsbausatz
Mod. DC-63



Mittelschwenklager
Mod. F



Montiert mit Kolbenstangenmutter U.

Zylinder Serie 63 - Profilrohr doppelwirkend

Versionen: 63MP2... und 63LP2...



+ Hub

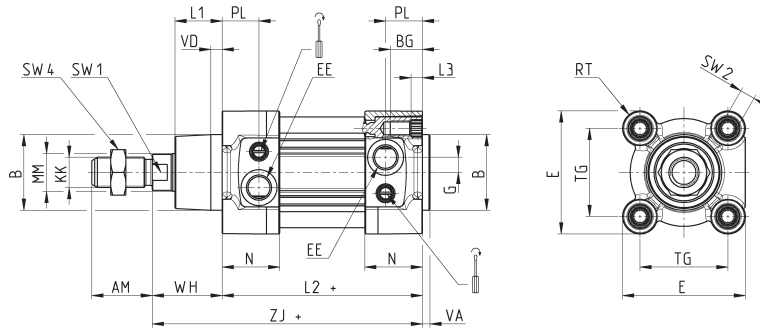

PRODUKTÜBERSICHT

| Ø | ØMM | KK | ØB | PL | L1 | AM | VA | EE | WH | L2 | L3 | ZJ | VD | N | BG | RT | G | TG | E | SW1 | SW2 | SW4 | Dämpfungshub vorn/hinten |
|-----|-----|----------|----|------|----|----|----|------|----|-----|-----|-----|----|------|------|-----|------|------|-----|-----|-----|-----|--------------------------|
| 32 | 12 | M10x1.25 | 30 | 18.5 | 18 | 22 | 4 | G1/8 | 26 | 94 | 5.5 | 120 | 5 | 27 | 16 | M6 | 5 | 32.5 | 47 | 10 | 6 | 17 | 17 |
| 40 | 16 | M12x1.25 | 35 | 19 | 21 | 24 | 4 | G1/4 | 30 | 105 | 5.5 | 135 | 5 | 30 | 16 | M6 | 5 | 38 | 55 | 13 | 6 | 19 | 18 |
| 50 | 20 | M16x1.5 | 40 | 19.5 | 25 | 32 | 4 | G1/4 | 37 | 106 | 6 | 143 | 6 | 30.5 | 16 | M8 | 8 | 46.5 | 65 | 17 | 8 | 24 | 20 |
| 63 | 20 | M16x1.5 | 45 | 24 | 26 | 32 | 4 | G3/8 | 37 | 121 | 6 | 158 | 6 | 37.5 | 16 | M8 | 8 | 56.5 | 75 | 17 | 8 | 24 | 22 |
| 80 | 25 | M20x1.5 | 45 | 23.5 | 30 | 40 | 4 | G3/8 | 46 | 128 | 0 | 174 | 7 | 37 | 19 | M10 | 8 | 72 | 93 | 22 | 6 | 30 | 25 |
| 100 | 25 | M20x1.5 | 55 | 24 | 35 | 40 | 4 | G1/2 | 51 | 138 | 0 | 189 | 7 | 39.5 | 19.5 | M10 | 8 | 89 | 110 | 22 | 6 | 30 | 26 |
| 125 | 32 | M27x2 | 60 | 28 | 42 | 54 | 6 | G1/2 | 65 | 160 | 6 | 225 | 8 | 44 | 23 | M12 | 10.5 | 110 | 135 | 27 | 12 | 41 | 33 |

Zylinder Serie 63 - Rundrohr doppelwirkend

Versionen: 63MT2... und 63LT2...



+ Hub

Hinweis zur Tabelle
* = Demontagewerkzeug 80-62/8C (siehe Zubehör)

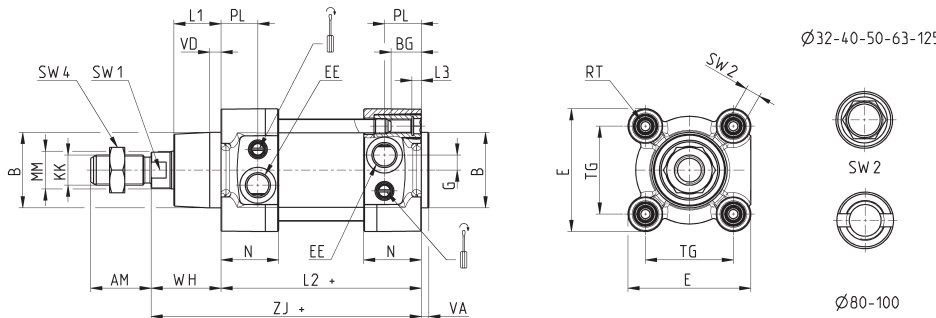

PRODUKTÜBERSICHT

| Ø | ØMM | KK | ØB | PL | L1 | AM | VA | EE | WH | L2 | L3 | ZJ | VD | N | BG | RT | G | TG | E | SW1 | SW2 | SW4 | Dämpfungshub vorn/hinten |
|-----|-----|----------|----|------|----|----|----|------|----|-----|-----|-----|----|------|------|-----|------|------|-----|-----|-----|-----|--------------------------|
| 32 | 12 | M10x1.25 | 30 | 18.5 | 18 | 22 | 4 | G1/8 | 26 | 94 | 5.5 | 120 | 5 | 27 | 16 | M6 | 5 | 32.5 | 47 | 10 | 6 | 17 | 17 |
| 40 | 16 | M12x1.25 | 35 | 19 | 21 | 24 | 4 | G1/4 | 30 | 105 | 5.5 | 135 | 5 | 30 | 16 | M6 | 5 | 38 | 55 | 13 | 6 | 19 | 18 |
| 50 | 20 | M16x1.5 | 40 | 19.5 | 25 | 32 | 4 | G1/4 | 37 | 106 | 6 | 143 | 6 | 30.5 | 16 | M8 | 8 | 46.5 | 65 | 17 | 8 | 24 | 20 |
| 63 | 20 | M16x1.5 | 45 | 24 | 26 | 32 | 4 | G3/8 | 37 | 121 | 6 | 158 | 6 | 37.5 | 16 | M8 | 8 | 56.5 | 75 | 17 | 8 | 24 | 22 |
| 80 | 25 | M20x1.5 | 45 | 23.5 | 30 | 40 | 4 | G3/8 | 46 | 128 | 0 | 174 | 7 | 37 | 19 | M10 | 8 | 72 | 93 | 22 | * | 30 | 25 |
| 100 | 25 | M20x1.5 | 55 | 24 | 35 | 40 | 4 | G1/2 | 51 | 138 | 0 | 189 | 7 | 39.5 | 19.5 | M10 | 8 | 89 | 110 | 22 | * | 30 | 26 |
| 125 | 32 | M27x2 | 60 | 28 | 42 | 54 | 6 | G1/2 | 65 | 160 | 6 | 225 | 8 | 44 | 23 | M12 | 10.5 | 110 | 135 | 27 | 12 | 41 | 33 |

Zylinder Serie 63 - Profilrohr einfachwirkend, Feder vorne

Versionen: 63MP1... und 63LP1...



+ Hub

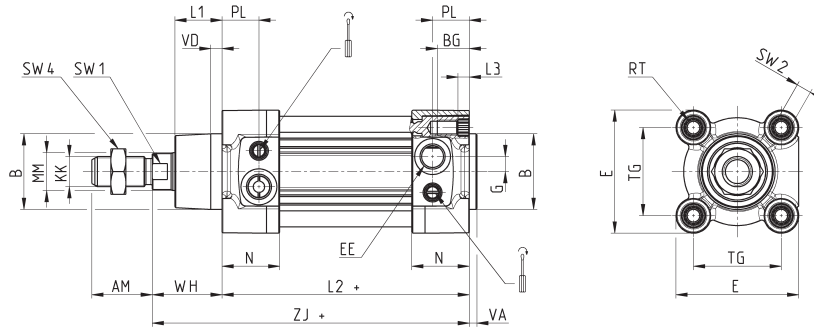

| PRODUKTÜBERSICHT | | | | | | | | | | | | | | | | | | | | | | | | | | | |
|------------------|-----|----------|----|------|----|----|----|------|----|-----|-----|-----|----|------|------|-----|------|------|-----|-----|-----|-----|--------------------------|--|--|--|--|
| Ø | ØMM | KK | ØB | PL | L1 | AM | VA | EE | WH | L2 | L3 | ZJ | VD | N | BG | RT | G | TG | E | SW1 | SW2 | SW4 | Dämpfungshub vorn/hinten | | | | |
| 32 | 12 | M10x1.25 | 30 | 18.5 | 18 | 22 | 4 | G1/8 | 26 | 119 | 5.5 | 145 | 5 | 27 | 16 | M6 | 5 | 32.5 | 47 | 10 | 6 | 17 | 17 | | | | |
| 40 | 16 | M12x1.25 | 35 | 19 | 21 | 24 | 4 | G1/4 | 30 | 130 | 5.5 | 160 | 5 | 30 | 16 | M6 | 5 | 38 | 55 | 13 | 6 | 19 | 18 | | | | |
| 50 | 20 | M16x1.5 | 40 | 19.5 | 25 | 32 | 4 | G1/4 | 37 | 131 | 6 | 168 | 6 | 30.5 | 16 | M8 | 8 | 46.5 | 65 | 17 | 8 | 24 | 20 | | | | |
| 63 | 20 | M16x1.5 | 45 | 24 | 26 | 32 | 4 | G3/8 | 37 | 146 | 6 | 183 | 6 | 37.5 | 16 | M8 | 8 | 56.5 | 75 | 17 | 8 | 24 | 22 | | | | |
| 80 | 25 | M20x1.5 | 45 | 23.5 | 30 | 40 | 4 | G3/8 | 46 | 153 | 0 | 199 | 7 | 37 | 19 | M10 | 8 | 72 | 93 | 22 | 6 | 30 | 25 | | | | |
| 100 | 25 | M20x1.5 | 55 | 24 | 35 | 40 | 4 | G1/2 | 51 | 163 | 0 | 214 | 7 | 39.5 | 19.5 | M10 | 8 | 89 | 110 | 22 | 6 | 30 | 26 | | | | |
| 125 | 32 | M27x2 | 60 | 28 | 42 | 54 | 6 | G1/2 | 65 | 185 | 6 | 250 | 8 | 44 | 23 | M12 | 10.5 | 110 | 135 | 27 | 12 | 41 | 33 | | | | |

Zylinder Serie 63 - Profilrohr einfachwirkend, Feder hinten

Versionen: 63MP9... und 63LP9...



+ Hub
++ = 2x Hub

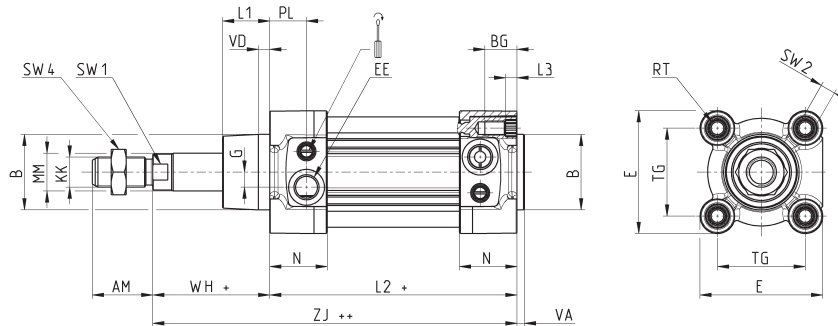

| PRODUKTÜBERSICHT | | | | | | | | | | | | | | | | | | | | | | | | | | | |
|------------------|-----|----------|----|------|----|----|----|------|----|-----|-----|-----|----|------|------|-----|------|------|-----|-----|-----|-----|--------------------------|--|--|--|--|
| Ø | ØMM | KK | ØB | PL | L1 | AM | VA | EE | WH | L2 | L3 | ZJ | VD | N | BG | RT | G | TG | E | SW1 | SW2 | SW4 | Dämpfungshub vorn/hinten | | | | |
| 32 | 12 | M10x1.25 | 30 | 18.5 | 18 | 22 | 4 | G1/8 | 51 | 119 | 5.5 | 170 | 5 | 27 | 16 | M6 | 5 | 32.5 | 47 | 10 | 6 | 17 | 17 | | | | |
| 40 | 16 | M12x1.25 | 35 | 19 | 21 | 24 | 4 | G1/4 | 55 | 130 | 5.5 | 185 | 5 | 30 | 16 | M6 | 5 | 38 | 55 | 13 | 6 | 19 | 18 | | | | |
| 50 | 20 | M16x1.5 | 40 | 19.5 | 25 | 32 | 4 | G1/4 | 62 | 131 | 6 | 193 | 6 | 30.5 | 16 | M8 | 8 | 46.5 | 65 | 17 | 8 | 24 | 20 | | | | |
| 63 | 20 | M16x1.5 | 45 | 24 | 26 | 32 | 4 | G3/8 | 62 | 146 | 6 | 208 | 6 | 37.5 | 16 | M8 | 8 | 56.5 | 75 | 17 | 8 | 24 | 22 | | | | |
| 80 | 25 | M20x1.5 | 45 | 23.5 | 30 | 40 | 4 | G3/8 | 71 | 153 | 0 | 224 | 7 | 37 | 19 | M10 | 8 | 72 | 93 | 22 | 6 | 30 | 25 | | | | |
| 100 | 25 | M20x1.5 | 55 | 24 | 35 | 40 | 4 | G1/2 | 76 | 163 | 0 | 239 | 7 | 39.5 | 19.5 | M10 | 8 | 89 | 110 | 22 | 6 | 30 | 26 | | | | |
| 125 | 32 | M27x2 | 60 | 28 | 42 | 54 | 6 | G1/2 | 90 | 185 | 6 | 275 | 8 | 44 | 23 | M12 | 10.5 | 110 | 135 | 27 | 12 | 41 | 33 | | | | |

Zylinder Serie 63 - Rundrohr einfachwirkend, Feder vorne

Versionen 63MT1... und 63LT1...



+ Hub

Hinweis zur Tabelle
* = Demontagewerkzeug 80-62/8C (siehe Zubehör)

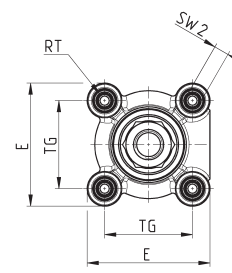
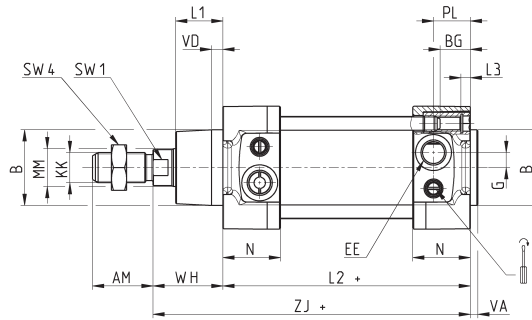

Ø32-40-50-63-125



Ø80-100

| PRODUKTÜBERSICHT | | | | | | | | | | | | | | | | | | | | | | | |
|------------------|-----|----------|----|------|----|----|----|------|----|-----|----|-----|----|------|------|-----|------|------|-----|-----|-----|-----|--------------------------|
| Ø | ØMM | KK | ØB | PL | L1 | AM | VA | EE | WH | L2 | L3 | ZJ | VD | N | BG | RT | G | TG | E | SW1 | SW2 | SW4 | Dämpfungshub vorn/hinten |
| 32 | 12 | M10x1.25 | 30 | 18.5 | 18 | 22 | 4 | G1/8 | 26 | 119 | 5 | 145 | 5 | 27 | 16 | M6 | 5 | 32.5 | 47 | 10 | 6 | 17 | 17 |
| 40 | 16 | M12x1.25 | 35 | 19 | 21 | 24 | 4 | G1/4 | 30 | 130 | 5 | 160 | 5 | 30 | 16 | M6 | 5 | 38 | 55 | 13 | 6 | 19 | 18 |
| 50 | 20 | M16x1.5 | 40 | 19.5 | 25 | 32 | 4 | G1/4 | 37 | 131 | 5 | 168 | 6 | 30.5 | 16 | M8 | 8 | 46.5 | 65 | 17 | 8 | 24 | 20 |
| 63 | 20 | M16x1.5 | 45 | 24 | 26 | 32 | 4 | G3/8 | 37 | 146 | 5 | 183 | 6 | 37.5 | 16 | M8 | 8 | 56.5 | 75 | 17 | 8 | 24 | 22 |
| 80 | 25 | M20x1.5 | 45 | 23.5 | 30 | 40 | 4 | G3/8 | 46 | 153 | 0 | 199 | 7 | 37 | 19 | M10 | 8 | 72 | 93 | 22 | * | 30 | 25 |
| 100 | 25 | M20x1.5 | 55 | 24 | 35 | 40 | 4 | G1/2 | 51 | 163 | 0 | 214 | 7 | 39.5 | 19.5 | M10 | 8 | 89 | 110 | 22 | * | 30 | 26 |
| 125 | 32 | M27x2 | 60 | 28 | 42 | 54 | 6 | G1/2 | 65 | 185 | 6 | 250 | 8 | 44 | 23 | M12 | 10.5 | 110 | 135 | 27 | 12 | 41 | 33 |

Zylinder Serie 63 - Rundrohr einfachwirkend, Feder hinten

Versionen: 63MT9... und 63LT9...



+ Hub

Hinweis zur Tabelle
* = Demontagewerkzeug 80-62/8C (siehe Zubehör)

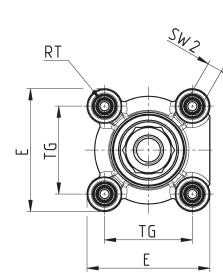
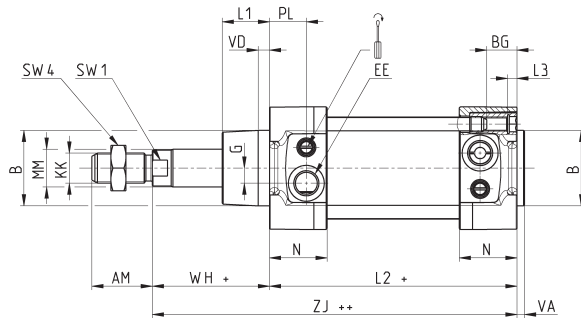

Ø32-40-50-63-125



Ø80-100

| PRODUKTÜBERSICHT | | | | | | | | | | | | | | | | | | | | | | | |
|------------------|-----|----------|----|------|----|----|----|------|----|-----|----|-----|----|------|------|-----|------|------|-----|-----|-----|-----|--------------------------|
| Ø | ØMM | KK | ØB | PL | L1 | AM | VA | EE | WH | L2 | L3 | ZJ | VD | N | BG | RT | G | TG | E | SW1 | SW2 | SW4 | Dämpfungshub vorn/hinten |
| 32 | 12 | M10x1.25 | 30 | 18.5 | 18 | 22 | 4 | G1/8 | 51 | 119 | 5 | 170 | 5 | 27 | 16 | M6 | 5 | 32.5 | 47 | 10 | 6 | 17 | 17 |
| 40 | 16 | M12x1.25 | 35 | 19 | 21 | 24 | 4 | G1/4 | 55 | 130 | 5 | 185 | 5 | 30 | 16 | M6 | 5 | 38 | 55 | 13 | 6 | 19 | 18 |
| 50 | 20 | M16x1.5 | 40 | 19.5 | 25 | 32 | 4 | G1/4 | 62 | 131 | 5 | 193 | 6 | 30.5 | 16 | M8 | 8 | 46.5 | 65 | 17 | 8 | 24 | 20 |
| 63 | 20 | M16x1.5 | 45 | 24 | 26 | 32 | 4 | G3/8 | 62 | 146 | 5 | 208 | 6 | 37.5 | 16 | M8 | 8 | 56.5 | 75 | 17 | 8 | 24 | 22 |
| 80 | 25 | M20x1.5 | 45 | 23.5 | 30 | 40 | 4 | G3/8 | 71 | 153 | 0 | 224 | 7 | 37 | 19 | M10 | 8 | 72 | 93 | 22 | * | 30 | 25 |
| 100 | 25 | M20x1.5 | 55 | 24 | 35 | 40 | 4 | G1/2 | 76 | 163 | 0 | 239 | 7 | 39.5 | 19.5 | M10 | 8 | 89 | 110 | 22 | * | 30 | 26 |
| 125 | 32 | M27x2 | 60 | 28 | 42 | 54 | 6 | G1/2 | 90 | 185 | 6 | 275 | 8 | 44 | 23 | M12 | 10.5 | 110 | 135 | 27 | 12 | 41 | 33 |

Zylinder Serie 63 - Profilrohr, durchgehende Kolbenstange

Versionen: 63MP6..., 63MP7..., 63LP6... und 63LP7...

Hinweis: Die Abmessungen L2 und ZM der einfachwirkenden Version erhöhen sich um 25 mm



+ Hub
++ 2 x Hub

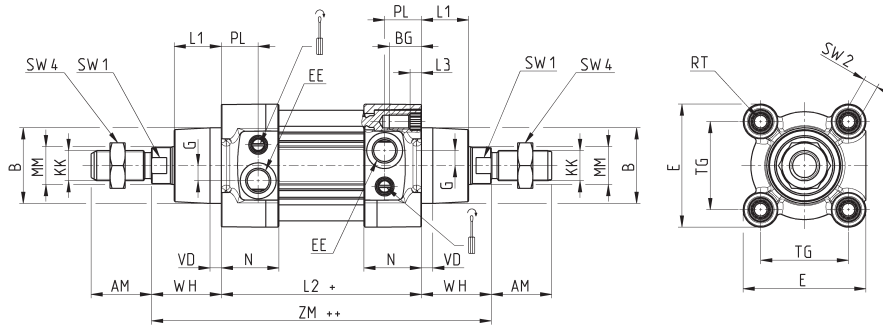

| PRODUKTÜBERSICHT | | | | | | | | | | | | | | | | | | | | | | | |
|------------------|-----|----------|----|------|----|----|------|----|-----|-----|-----|----|------|------|-----|------|------|-----|----|-----|-----|-----|--------------------------|
| Ø | ØMM | KK | ØB | PL | L1 | AM | EE | WH | L2 | L3 | ZM | VD | N | BG | RT | G | TG | E | ØF | SW1 | SW2 | SW4 | Dämpfungshub vorn/hinten |
| 32 | 12 | M10x1.25 | 30 | 18.5 | 18 | 22 | G1/8 | 26 | 94 | 5.5 | 146 | 5 | 27 | 16 | M6 | 5 | 32.5 | 47 | - | 10 | 6 | 17 | 17 |
| 40 | 16 | M12x1.25 | 35 | 19 | 21 | 24 | G1/4 | 30 | 105 | 5.5 | 165 | 5 | 30 | 16 | M6 | 5 | 38 | 55 | - | 13 | 6 | 19 | 18 |
| 50 | 20 | M16x1.5 | 40 | 19.5 | 25 | 32 | G1/4 | 37 | 106 | 6 | 180 | 6 | 30.5 | 16 | M8 | 8 | 46.5 | 65 | 8 | 17 | 8 | 24 | 20 |
| 63 | 20 | M16x1.5 | 45 | 24 | 26 | 32 | G3/8 | 37 | 121 | 6 | 195 | 6 | 37.5 | 16 | M8 | 8 | 56.5 | 75 | 8 | 17 | 8 | 24 | 22 |
| 80 | 25 | M20x1.5 | 45 | 23.5 | 30 | 40 | G3/8 | 46 | 128 | 0 | 220 | 7 | 37 | 19 | M10 | 8 | 72 | 93 | 8 | 22 | 6 | 30 | 25 |
| 100 | 25 | M20x1.5 | 55 | 24 | 35 | 40 | G1/2 | 51 | 138 | 0 | 240 | 7 | 39.5 | 19.5 | M10 | 8 | 89 | 110 | 8 | 22 | 6 | 30 | 26 |
| 125 | 32 | M27x2 | 60 | 28 | 42 | 54 | G1/2 | 65 | 160 | 6 | 290 | 8 | 44 | 23 | M12 | 10.5 | 110 | 135 | - | 27 | 12 | 41 | 33 |

Zylinder Serie 63 - Rundrohr, durchgehende Kolbenstange

Versionen: 63MT6..., 63MT7..., 63LT6... und 63LT7...

Hinweis: Die Abmessungen L2 und ZM der einfachwirkenden Version erhöhen sich um 25 mm



+ Hub
++ 2 x Hub

Hinweis zur Tabelle
* = Demontagewerkzeug 80-62/8C (siehe Zubehör)

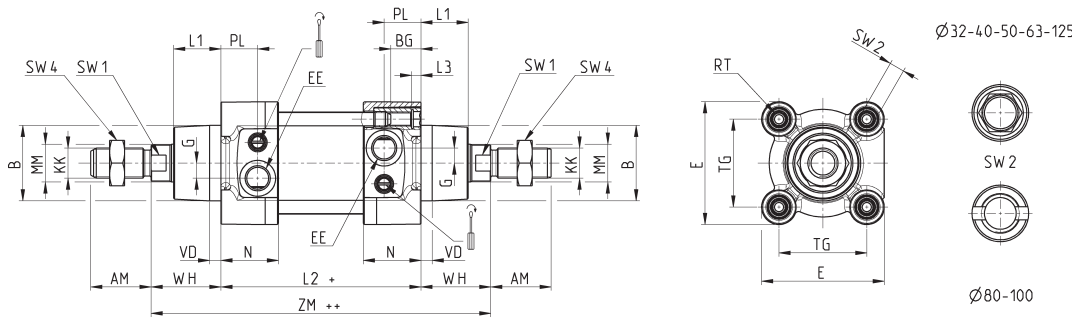

| PRODUKTÜBERSICHT | | | | | | | | | | | | | | | | | | | | | | | |
|------------------|-----|----------|----|------|----|----|------|----|-----|----|-----|----|------|------|-----|------|------|-----|----|-----|-----|-----|--------------------------|
| Ø | ØMM | KK | ØB | PL | L1 | AM | EE | WH | L2 | L3 | ZM | VD | N | BG | RT | G | TG | E | ØF | SW1 | SW2 | SW4 | Dämpfungshub vorn/hinten |
| 32 | 12 | M10x1.25 | 30 | 18.5 | 18 | 22 | G1/8 | 26 | 94 | 5 | 146 | 5 | 27 | 16 | M6 | 5 | 32.5 | 47 | - | 10 | 6 | 17 | 17 |
| 40 | 16 | M12x1.25 | 35 | 19 | 21 | 24 | G1/4 | 30 | 105 | 5 | 165 | 5 | 30 | 16 | M6 | 5 | 38 | 55 | - | 13 | 6 | 19 | 18 |
| 50 | 20 | M16x1.5 | 40 | 19.5 | 25 | 32 | G1/4 | 37 | 106 | 6 | 180 | 6 | 30.5 | 16 | M8 | 8 | 46.5 | 65 | 8 | 17 | 8 | 24 | 20 |
| 63 | 20 | M16x1.5 | 45 | 24 | 26 | 32 | G3/8 | 37 | 121 | 5 | 195 | 6 | 37.5 | 16 | M8 | 8 | 56.5 | 75 | 8 | 17 | 8 | 24 | 22 |
| 80 | 25 | M20x1.5 | 45 | 23.5 | 30 | 40 | G3/8 | 46 | 128 | 0 | 220 | 7 | 37 | 19 | M10 | 8 | 72 | 93 | 8 | 22 | * | 30 | 25 |
| 100 | 25 | M20x1.5 | 55 | 24 | 35 | 40 | G1/2 | 51 | 138 | 0 | 240 | 7 | 39.5 | 19.5 | M10 | 8 | 89 | 110 | 8 | 22 | * | 30 | 26 |
| 125 | 32 | M27x2 | 60 | 28 | 42 | 54 | G1/2 | 65 | 160 | 6 | 290 | 8 | 44 | 23 | M12 | 10.5 | 110 | 135 | - | 27 | 12 | 41 | 33 |

Zylinder Serie 63 - mit Feststelleinheit

Versionen: 63MT1... und 63LT1...

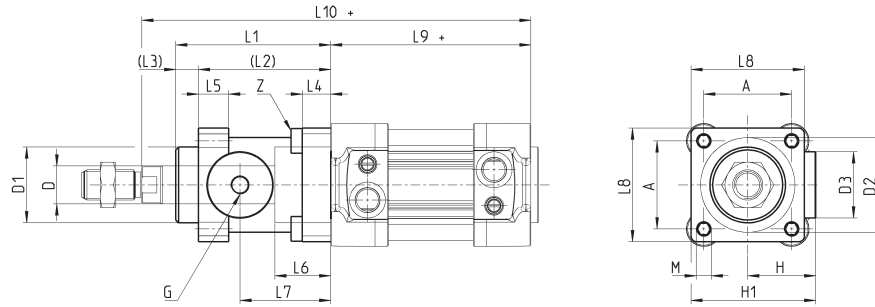

+ Hub

ZYLINDER ISO 15552 SERIE 63

| ∅ | \varnothing_D | \varnothing_{D1} | \varnothing_{D2} | \varnothing_{D3} | A | G | H | H1 | L1 | L2 | L3 | L4 | L5 | L6 | L7 | L8 | L9+ | L10+ | M | Z |
|-----|-----------------|--------------------|--------------------|--------------------|------|------|------|-------|-----|-----|----|----|----|------|------|-----|-----|------|-----|--------|
| 32 | 12 | 30.5 | 35 | 25 | 32.5 | M5 | 25.5 | 46.5 | 58 | 48 | 10 | 8 | 13 | 20.5 | 34 | 45 | 94 | 160 | M6 | M6X20 |
| 40 | 16 | 35 | 40 | 28 | 38 | G1/8 | 30 | 53 | 65 | 55 | 10 | 8 | 13 | 22.5 | 38 | 50 | 105 | 178 | M6 | M6X20 |
| 50 | 20 | 40 | 50 | 35 | 46.5 | G1/8 | 36 | 64 | 82 | 70 | 12 | 15 | 16 | 29.5 | 48 | 60 | 106 | 200 | M8 | M6X20 |
| 63 | 20 | 45 | 60 | 38 | 56.5 | G1/8 | 40 | 75 | 82 | 70 | 12 | 15 | 16 | 29.5 | 49.5 | 70 | 121 | 215 | M8 | M8X30 |
| 80 | 25 | 45 | 80 | 48 | 72 | G1/8 | 50 | 95 | 110 | 90 | 20 | 18 | 20 | 35 | 61 | 90 | 128 | 254 | M10 | M10X35 |
| 100 | 25 | 55 | 100 | 58 | 89 | G1/8 | 58 | 110.5 | 115 | 100 | 15 | 18 | 20 | 39 | 69 | 105 | 138 | 269 | M10 | M10X35 |
| 125 | 32 | 60 | 130 | 65 | 110 | G1/8 | 80 | 150 | 167 | 122 | 45 | 22 | 30 | 51 | 86.5 | 140 | 160 | 350 | M12 | M12X40 |

Zylinder Serie 63 - mit Kolbenstangen-Innengewinde

Neue Version

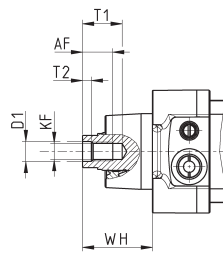

| PRODUKTÜBERSICHT | | | | | | |
|------------------|--------|----------|------|--------|-----|----|
| ∅ | AF Min | KF | D1 ∅ | T1 Max | T2 | WH |
| 32 | 12 | M6X1 | 6.4 | 16 | 2.6 | 26 |
| 40 | 12 | M8X1.25 | 8.4 | 16 | 3.3 | 30 |
| 50 | 16 | M10X1.5 | 10.5 | 21 | 4.7 | 37 |
| 63 | 16 | M10X1.5 | 10.5 | 21 | 4.7 | 37 |
| 80 | 20 | M12X1.75 | 13 | 26.5 | 6.1 | 46 |
| 100 | 20 | M12X1.75 | 13 | 26.5 | 6.1 | 54 |
| 125 | 32 | M16X2 | 17 | 40 | 8 | 65 |

Zylinder Serie 63 - Rundrohr, Tandemversion

Neue Version

+ Hub
++ 2x Hub

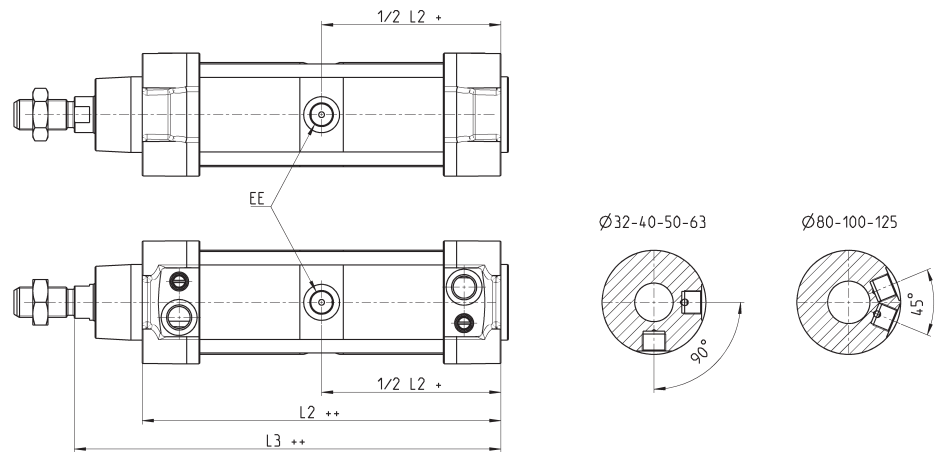

| PRODUKTÜBERSICHT | | | |
|------------------|------|-------|-------|
| Ø | EE | L2 | L3 |
| 32 | G1/8 | 171.5 | 197.5 |
| 40 | G1/4 | 191.5 | 221.5 |
| 50 | G1/4 | 188 | 225 |
| 63 | G3/8 | 204 | 241 |
| 80 | G3/8 | 225.5 | 271.5 |
| 100 | G1/2 | 231 | 282 |
| 125 | G1/2 | 264 | 329 |

Zylinder Serie 63 - Profilrohr, Tandemversion

Neue Version

+ Hub
++ 2x Hub

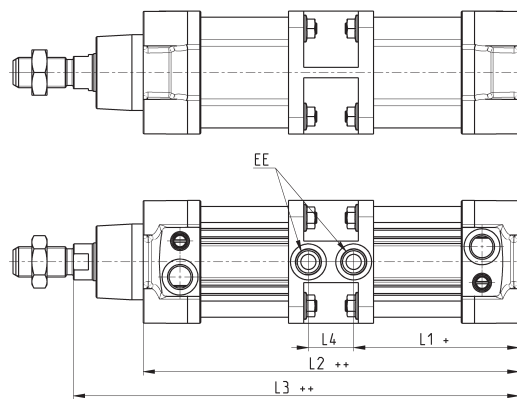

| PRODUKTÜBERSICHT | | | | | |
|------------------|------|-------|-------|-------|------|
| Ø | EE | L1 | L2 | L3 | L4 |
| 32 | G1/8 | 76.5 | 171.5 | 197.5 | 18.5 |
| 40 | G1/4 | 88.5 | 200 | 230 | 23 |
| 50 | G1/4 | 87.5 | 199 | 236 | 24 |
| 63 | G3/8 | 98 | 223 | 260 | 27 |
| 80 | G3/8 | 104.5 | 236 | 282 | 27 |
| 100 | G1/2 | 116 | 260 | 311 | 28 |
| 125 | G1/2 | 132 | 264 | 329 | 0 |

Zylinder Serie 63 - Rundrohr, Mehrstellungsversion

Neue Version

ZYLINDER ISO 15552 SERIE 63

+ Hub
++ 2x Hub

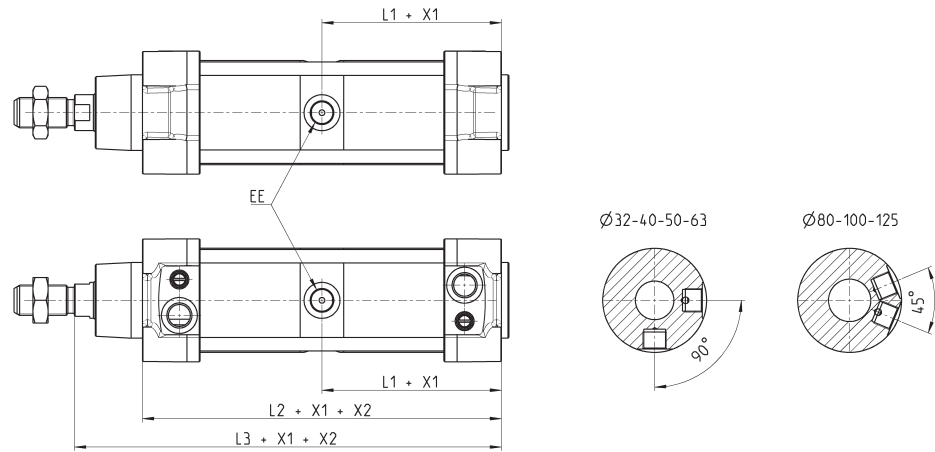

| PRODUKTÜBERSICHT | | | | |
|------------------|------|-------|-------|-------|
| Ø | EE | L1 | L2 | L3 |
| 32 | G1/8 | 86 | 171.5 | 197.5 |
| 40 | G1/4 | 96 | 191.5 | 221.5 |
| 50 | G1/4 | 94 | 188 | 225 |
| 63 | G3/8 | 102 | 204 | 241 |
| 80 | G3/8 | 113 | 225.5 | 271.5 |
| 100 | G1/2 | 115.5 | 231 | 282 |
| 125 | G1/2 | 132 | 264 | 329 |

Zylinder Serie 63 - Profilrohr, Mehrstellungsversion

Neue Version

+ Hub
++ 2x Hub

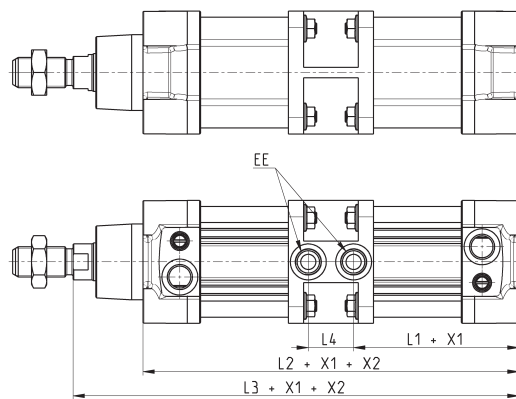

| PRODUKTÜBERSICHT | | | | | |
|------------------|------|-------|-------|-------|------|
| Ø | EE | L1 | L2 | L3 | L4 |
| 32 | G1/8 | 76.5 | 171.5 | 197.5 | 18.5 |
| 40 | G1/4 | 88.5 | 200 | 230 | 23 |
| 50 | G1/4 | 87.5 | 199 | 236 | 24 |
| 63 | G3/8 | 98 | 223 | 260 | 27 |
| 80 | G3/8 | 104.5 | 236 | 282 | 27 |
| 100 | G1/2 | 116 | 260 | 311 | 28 |
| 125 | G1/2 | 132 | 264 | 329 | 0 |

Zylinder Serie 63 - Kolbenstange mit Faltenblag

Neue Version

+ Hub
++ 2x Hub

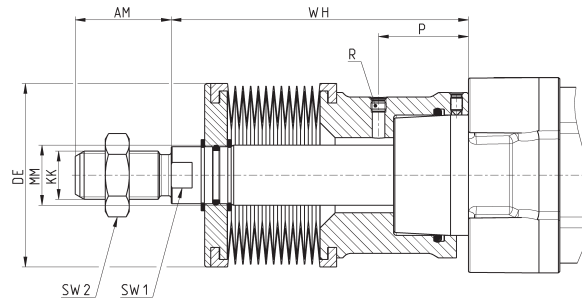

| PRODUKTÜBERSICHT | | | | | | | | | | |
|------------------|-----------|-----|----|----------|----|------|------|-----|-----|--|
| Ø | Hub | WH | AM | KK | MM | P | R | SW1 | SW2 | |
| 32 | 0 ÷ 245 | 88 | 22 | M10X1.25 | 12 | 25 | M5 | 10 | 17 | |
| 32 | 246 ÷ 490 | 132 | 22 | M10X1.25 | 12 | 25 | M5 | 10 | 17 | |
| 40 | 0 ÷ 245 | 89 | 24 | M12X1.25 | 16 | 26 | M5 | 13 | 19 | |
| 40 | 246 ÷ 490 | 133 | 24 | M12X1.25 | 16 | 26 | M5 | 13 | 19 | |
| 50 | 0 ÷ 245 | 99 | 32 | M16X1.5 | 20 | 30 | M5 | 17 | 24 | |
| 50 | 246 ÷ 490 | 143 | 32 | M16X1.5 | 20 | 30 | M5 | 17 | 24 | |
| 63 | 0 ÷ 245 | 76 | 32 | M16X1.5 | 20 | 16.5 | M5 | 17 | 24 | |
| 63 | 246 ÷ 490 | 120 | 32 | M16X1.5 | 20 | 16.5 | M5 | 17 | 24 | |
| 80 | 0 ÷ 285 | 86 | 40 | M20X1.5 | 25 | 11.5 | G1/8 | 22 | 30 | |
| 80 | 286 ÷ 570 | 139 | 40 | M20X1.5 | 25 | 11.5 | G1/8 | 22 | 30 | |
| 100 | 0 ÷ 285 | 86 | 40 | M20X1.5 | 25 | 12 | G1/8 | 22 | 30 | |
| 100 | 286 ÷ 570 | 139 | 40 | M20X1.5 | 25 | 12 | G1/8 | 22 | 30 | |
| 125 | 0 ÷ 285 | 108 | 54 | M27X2 | 32 | 30 | G1/8 | 29 | 41 | |
| 125 | 286 ÷ 570 | 161 | 54 | M27X2 | 32 | 30 | G1/8 | 29 | 41 | |

Zylinder Serie 63 - Rundrohr, Boden/Boden-Montage

Neue Version

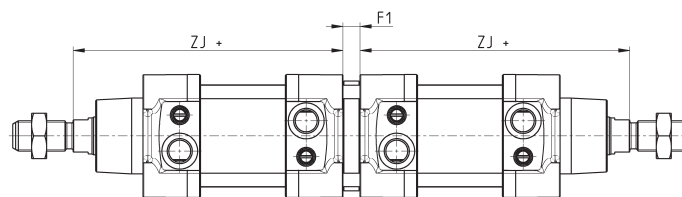

| PRODUKTÜBERSICHT | | | |
|------------------|----|-----|------|
| Ø | F1 | ZJ+ | |
| 32 | 9 | 120 | 500 |
| 40 | 9 | 135 | 800 |
| 50 | 9 | 143 | 800 |
| 63 | 9 | 158 | 700 |
| 80 | 9 | 174 | 1000 |
| 100 | 9 | 189 | 900 |
| 125 | 20 | 225 | 1000 |

Mehrstellungsbausatz Mod. DC-63

Werkstoff: Aluminium



Lieferumfang:
1 Flansch
8 Madenschrauben
8 Muttern

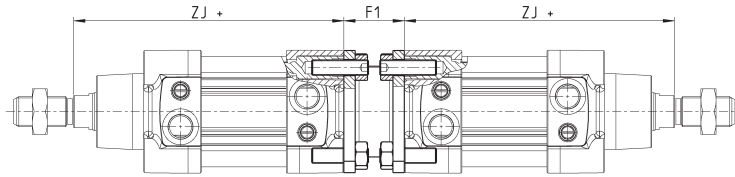

ZYLINDER ISO 15552 SERIE 63

PRODUKTÜBERSICHT

| Mod. | ∅ | F1 | ZJ+ | Gewicht (g) | Gesamthub max. (mm) | Anzugsdrehmoment |
|-----------|-----|----|-----|-------------|---------------------|------------------|
| DC-63-32 | 32 | 27 | 120 | 130 | 500 | 5 Nm |
| DC-63-40 | 40 | 27 | 135 | 160 | 800 | 5 Nm |
| DC-63-50 | 50 | 32 | 143 | 285 | 800 | 10 Nm |
| DC-63-63 | 63 | 28 | 158 | 340 | 700 | 10 Nm |
| DC-63-80 | 80 | 38 | 174 | 670 | 1000 | 15 Nm |
| DC-63-100 | 100 | 38 | 189 | 820 | 900 | 15 Nm |
| DC-63-125 | 125 | 48 | 225 | 1300 | 1000 | 20 Nm |

Fußbefestigung Mod. B-41

Werkstoff: Stahl verzinkt



Lieferumfang:
2 Fußbefestigungen
4 Schrauben

+ Hub

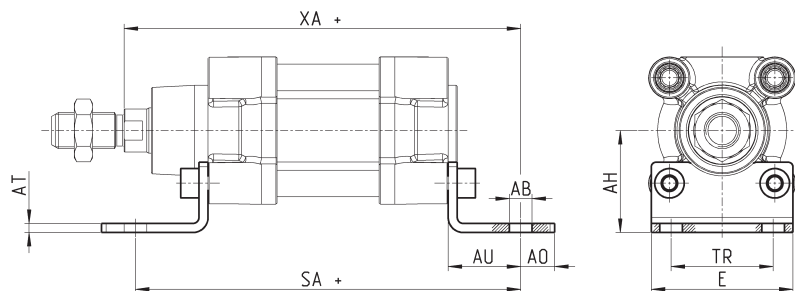

PRODUKTÜBERSICHT

| Mod. | ∅ | AT | SA+ | XA+ | TR | E | AB | AH | AO | AU | Anzugsdrehmoment |
|----------|-----|----|-----|-----|----|-------|------|----|----|----|------------------|
| B-41-32 | 32 | 4 | 142 | 144 | 32 | 45 | 7 | 32 | 11 | 24 | 5 Nm |
| B-41-40 | 40 | 4 | 161 | 163 | 36 | 53,5 | 10 | 36 | 15 | 28 | 5 Nm |
| B-41-50 | 50 | 4 | 170 | 175 | 45 | 62,5 | 10 | 45 | 15 | 32 | 10 Nm |
| B-41-63 | 63 | 5 | 185 | 190 | 50 | 73 | 10 | 50 | 15 | 32 | 10 Nm |
| B-41-80 | 80 | 6 | 210 | 216 | 63 | 92 | 12 | 63 | 20 | 41 | 15 Nm |
| B-41-100 | 100 | 6 | 220 | 230 | 75 | 108,5 | 14,5 | 71 | 25 | 41 | 15 Nm |
| B-41-125 | 125 | 7 | 250 | 270 | 90 | 132 | 16,5 | 90 | 25 | 45 | 20 Nm |

Flansch vorn oder hinten Mod. D-E

Werkstoff: Aluminium

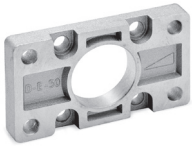

Lieferumfang:
1 Flansch
4 Schrauben
+ Hub

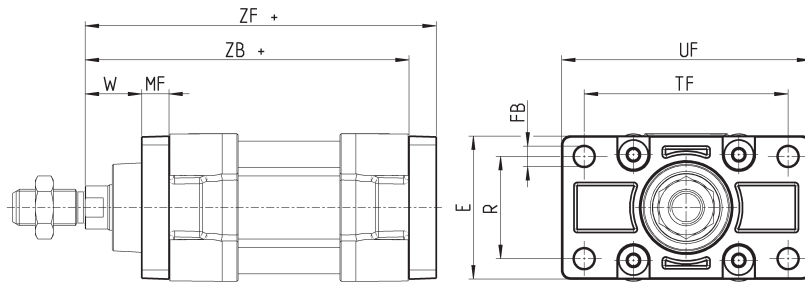

| PRODUKTÜBERSICHT | | | | | | | | | | | |
|------------------|-----|----|----|-----|-----|----|-----|-----|----|-----|------------------|
| Mod. | ∅ | W | MF | ZB+ | TF | R | UF | E | FB | ZF+ | Anzugsdrehmoment |
| D-E-41-32 | 32 | 16 | 10 | 120 | 64 | 32 | 86 | 45 | 7 | 130 | 5 Nm |
| D-E-41-40 | 40 | 20 | 10 | 135 | 72 | 36 | 88 | 52 | 9 | 145 | 5 Nm |
| D-E-41-50 | 50 | 25 | 12 | 143 | 90 | 45 | 110 | 63 | 9 | 155 | 10 Nm |
| D-E-41-63 | 63 | 25 | 12 | 158 | 100 | 50 | 116 | 73 | 9 | 170 | 10 Nm |
| D-E-41-80 | 80 | 30 | 16 | 174 | 126 | 63 | 148 | 95 | 12 | 190 | 15 Nm |
| D-E-41-100 | 100 | 35 | 16 | 189 | 150 | 75 | 176 | 115 | 14 | 205 | 15 Nm |
| D-E-41-125 | 125 | 45 | 20 | 225 | 180 | 90 | 224 | 135 | 16 | 245 | 20 Nm |

Schwenkgabel hinten Mod. C und C-H

Werkstoff: Aluminium

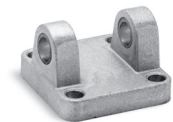

Lieferumfang:
1 Schwenkgabel
4 Schrauben
+ Hub

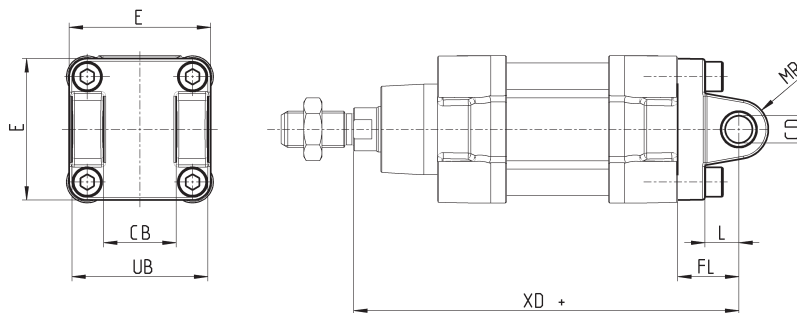

| PRODUKTÜBERSICHT | | | | | | | | | | |
|------------------|-----|----|----|----|-----|----|-------|----|-----|------------------|
| Mod. | ∅ | CD | L | FL | XD+ | MR | E | CB | UB | Anzugsdrehmoment |
| C-41-32 | 32 | 10 | 12 | 22 | 142 | 10 | 45 | 26 | 45 | 5 Nm |
| C-41-40 | 40 | 12 | 15 | 25 | 160 | 12 | 53.5 | 28 | 52 | 5 Nm |
| C-41-50 | 50 | 12 | 15 | 27 | 170 | 13 | 62.5 | 32 | 60 | 10 Nm |
| C-H-41-63 | 63 | 16 | 20 | 32 | 190 | 17 | 73 | 40 | 70 | 10 Nm |
| C-H-41-80 | 80 | 16 | 24 | 36 | 210 | 17 | 92 | 50 | 90 | 15 Nm |
| C-H-41-100 | 100 | 20 | 29 | 41 | 230 | 21 | 108.5 | 60 | 110 | 15 Nm |
| C-H-41-125 | 125 | 25 | 30 | 50 | 275 | 26 | 132 | 70 | 130 | 20 Nm |

Schwenkgabel vorne Mod. H und C-H

Werkstoff: Aluminium

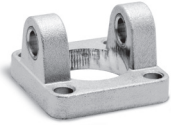

Lieferumfang:
1 Schwenkgabel
4 Schrauben

+ Hub

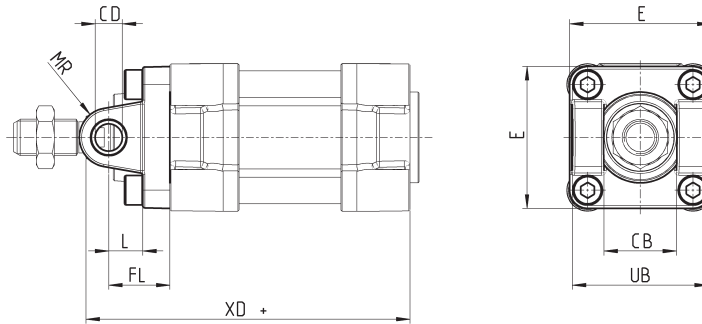

ZYLINDER ISO 15552 SERIE 63

PRODUKTÜBERSICHT

| Mod. | ∅ | CB | UB | E | XD | FL | L | CD | MR | Anzugsdrehmoment |
|------------|-----|----|-----|-------|-----|----|----|----|----|------------------|
| H-41-32 | 32 | 26 | 45 | 45 | 120 | 22 | 12 | 10 | 10 | 5 Nm |
| H-41-40 | 40 | 28 | 52 | 53.5 | 135 | 25 | 15 | 12 | 12 | 5 Nm |
| H-41-50 | 50 | 32 | 60 | 62.5 | 143 | 27 | 15 | 12 | 13 | 10 Nm |
| H-60-63 | 63 | 40 | 70 | 73 | 158 | 32 | 20 | 16 | 17 | 10 Nm |
| C-H-41-80 | 80 | 50 | 90 | 92 | 174 | 36 | 24 | 16 | 17 | 15 Nm |
| C-H-41-100 | 100 | 60 | 110 | 108.5 | 189 | 41 | 29 | 20 | 21 | 15 Nm |
| C-H-41-125 | 125 | 70 | 130 | 132 | 225 | 50 | 30 | 25 | 26 | 20 Nm |

Schwenklager hinten Mod. L

Werkstoff: Aluminium

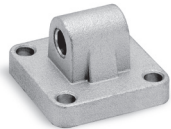

Lieferumfang:
1 Schwenklager
4 Schrauben

+ Hub

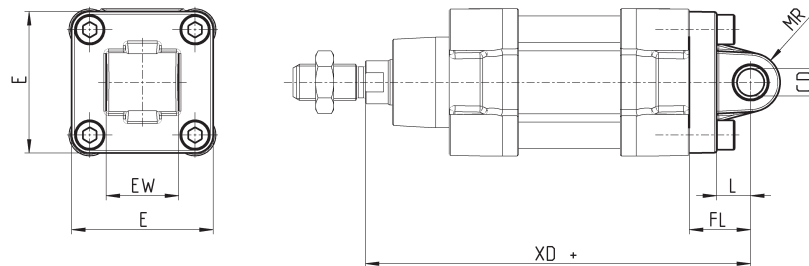

PRODUKTÜBERSICHT

| Mod. | ∅ | CD | L | FL | XD+ | MR | E | EW | Anzugsdrehmoment |
|----------|-----|----|----|----|-----|----|-------|----|------------------|
| L-41-32 | 32 | 10 | 12 | 22 | 142 | 10 | 45 | 26 | 5 Nm |
| L-41-40 | 40 | 12 | 15 | 25 | 160 | 13 | 53.5 | 28 | 5 Nm |
| L-41-50 | 50 | 12 | 15 | 27 | 170 | 13 | 62.5 | 32 | 10 Nm |
| L-41-63 | 63 | 16 | 20 | 32 | 190 | 17 | 73 | 40 | 10 Nm |
| L-41-80 | 80 | 16 | 24 | 36 | 210 | 17 | 92 | 50 | 15 Nm |
| L-41-100 | 100 | 20 | 29 | 41 | 230 | 21 | 108.5 | 60 | 15 Nm |
| L-41-125 | 125 | 25 | 30 | 50 | 275 | 26 | 132 | 70 | 20 Nm |

Mittelschwenklager vorne Mod. FN

Werkstoff: Stahl verzinkt

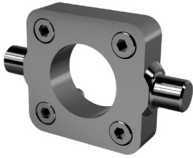

Lieferumfang:
1 Mittelschwenklager
4 Schrauben

+ Hub

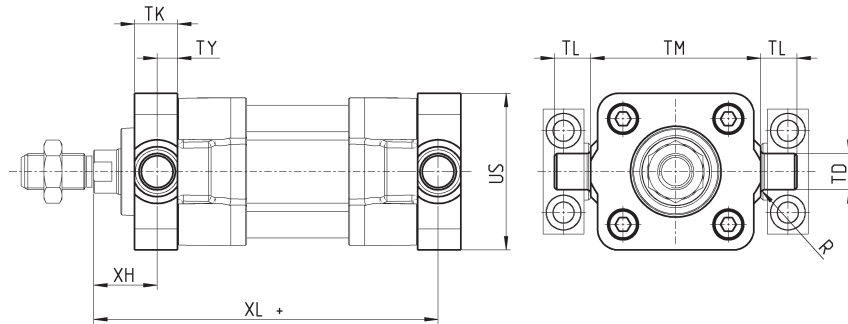

| PRODUKTÜBERSICHT | | | | | | | | | | | |
|------------------|-----|----|------|------|-------|-----|----|-----|----|-----|------------------|
| Mod. | ∅ | TK | TY | XH | XL | US | TL | TM | TD | R | Anzugsdrehmoment |
| FN-32 | 32 | 14 | 6.5 | 19.5 | 126.5 | 46 | 12 | 50 | 12 | 1 | 5 Nm |
| FN-40 | 40 | 19 | 9 | 21 | 144 | 59 | 16 | 63 | 16 | 1.5 | 5 Nm |
| FN-50 | 50 | 19 | 9 | 28 | 152 | 69 | 16 | 75 | 16 | 1.6 | 10 Nm |
| FN-63 | 63 | 24 | 11.5 | 25.5 | 169.5 | 84 | 20 | 90 | 20 | 1.6 | 10 Nm |
| FN-80 | 80 | 24 | 11.5 | 34.5 | 185.5 | 102 | 20 | 110 | 20 | 1.6 | 15 Nm |
| FN-100 | 100 | 29 | 14 | 37 | 203 | 125 | 25 | 132 | 25 | 2 | 15 Nm |
| FN-125 | 125 | 30 | 15 | 50 | 240 | 150 | 25 | 160 | 25 | 2 | 20 Nm |

Schwenklager sphärisch Mod. R

Werkstoff: Aluminium
* nicht genormt

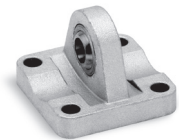

Lieferumfang:
1 Schwenklager
4 Schrauben

+ Hub

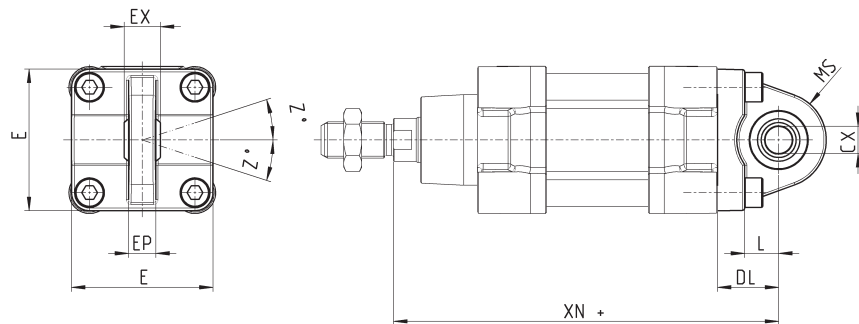

| PRODUKTÜBERSICHT | | | | | | | | | | | |
|------------------|-----|------|----|----|-----|----|-------|------|------|---|------------------|
| Mod. | ∅ | ∅CX | L | DL | XN+ | MS | E | EX | EP | Z | Anzugsdrehmoment |
| R-41-32 | 32 | 10 | 12 | 22 | 142 | 18 | 45 | 14 | 10.5 | 4 | 5 Nm |
| R-41-40 | 40 | 12 | 15 | 25 | 160 | 18 | 53.5 | 16 | 12 | 4 | 5 Nm |
| R-41-50 | 50 | 12 * | 15 | 27 | 170 | 21 | 62.5 | 16 * | 12 * | 4 | 10 Nm |
| R-41-63 | 63 | 16 | 20 | 32 | 190 | 23 | 73 | 21 | 15 | 4 | 10 Nm |
| R-41-80 | 80 | 16 * | 24 | 36 | 210 | 28 | 92 | 21 * | 15 * | 4 | 15 Nm |
| R-41-100 | 100 | 20 | 29 | 41 | 230 | 30 | 108.5 | 25 | 18 | 4 | 15 Nm |
| R-41-125 | 125 | 30 | 30 | 50 | 275 | 40 | 140 | 37 | 25 | 4 | 20 Nm |

Mittelschwenklager Mod. F (Rundrohr)



Werkstoff: Stahl verzinkt

Lieferumfang:
1 Mittelschwenklager
8 Madenschrauben

+ Hub

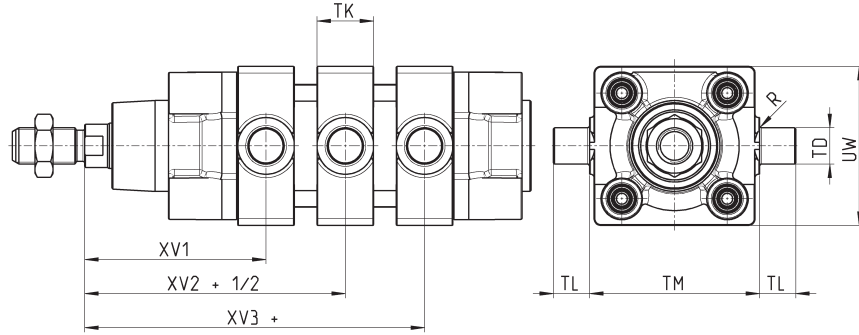

| PRODUKTÜBERSICHT | | | | | | | | | | |
|------------------|-----|-------|------|-------|----------|----|---------|----|-----|-----|
| Mod. | ∅ | XV1 | XV2 | XV3 | TM (h14) | TK | TD (e9) | TL | UW | R |
| F-32 | 32 | 63 | 73 | 83 | 50 | 20 | 12 | 12 | 50 | 0.5 |
| F-40 | 40 | 70 | 82,5 | 95 | 63 | 20 | 16 | 16 | 60 | 1 |
| F-50 | 50 | 80 | 90 | 100 | 75 | 25 | 16 | 16 | 70 | 1 |
| F-63 | 63 | 87 | 97,5 | 108 | 90 | 25 | 20 | 20 | 85 | 1 |
| F-80 | 80 | 98 | 110 | 122 | 110 | 30 | 20 | 20 | 105 | 1 |
| F-100 | 100 | 105,5 | 120 | 134,5 | 132 | 30 | 25 | 25 | 125 | 1.5 |
| F-125 | 125 | 124 | 145 | 166 | 160 | 30 | 25 | 25 | 155 | 1.5 |

Mittelschwenklager Mod. F-63 (Profilrohr)



Werkstoff: Stahl verzinkt

Lieferumfang:
1 Mittelschwenklager
8 Madenschrauben
2 Befestigungselemente

+ Hub

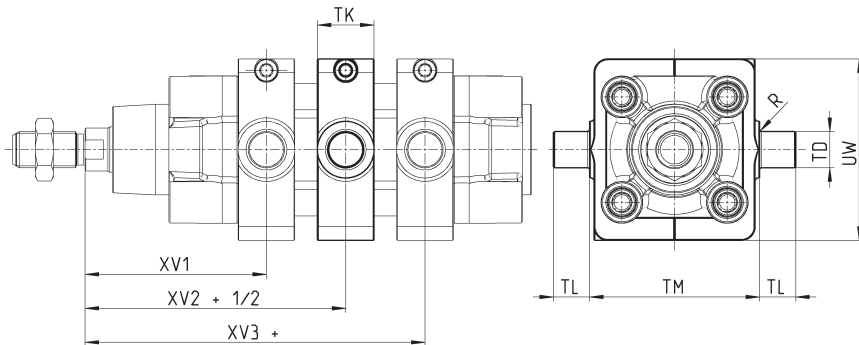

| PRODUKTÜBERSICHT | | | | | | | | | | |
|------------------|-----|-------|------|-------|-----|----|----|----|-----|-----|
| Mod. | ∅ | XV1 | XV2 | XV3 | TM | TK | TD | TL | UW | R |
| F-63-32 | 32 | 63 | 73 | 83 | 50 | 20 | 12 | 12 | 62 | 0.5 |
| F-63-40 | 40 | 70 | 82.5 | 95 | 61 | 20 | 16 | 16 | 70 | 1 |
| F-63-50 | 50 | 80 | 90 | 100 | 71 | 25 | 16 | 16 | 91 | 1 |
| F-63-63 | 63 | 87 | 97.5 | 108 | 84 | 25 | 20 | 20 | 90 | 1 |
| F-63-80 | 80 | 98 | 110 | 122 | 106 | 30 | 20 | 20 | 115 | 1 |
| F-63-100 | 100 | 105.5 | 120 | 134.5 | 128 | 30 | 25 | 25 | 135 | 1.5 |
| F-63-125 | 125 | 124 | 145 | 166 | 156 | 30 | 25 | 25 | 162 | 1.5 |

Montagebeispiel Kombination Mod. C, L, S

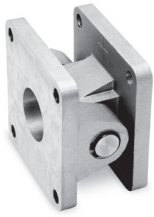

Werkstoff: Aluminium; Bestellbeispiel Ø 32): 1 Schwenkgabel (C-41-32), 1 Schwenklager (L-41-32), 1 Lagerbolzen (S-32) (müssen jeweils einzeln bestellt werden)

+ Hub

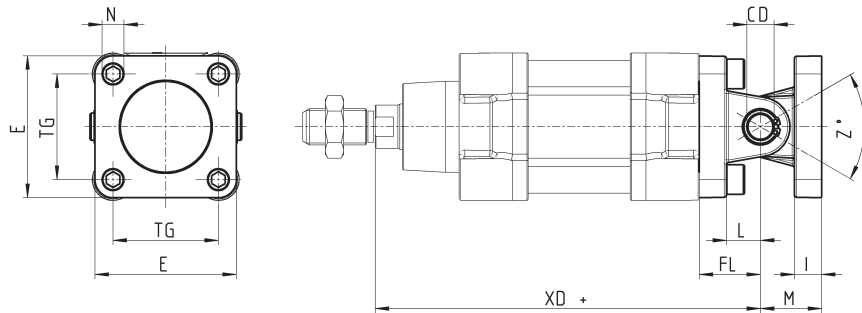

| ABMESSUNGEN | | | | | | | | | | | | |
|-------------|-----|-------|------|-----------------|-----|------------------|----|----|----|----|----------|------------------|
| Mod. | Ø | E | TG | $\varnothing N$ | XD+ | $\varnothing CD$ | L | FL | I | M | Z° (max) | Anzugsdrehmoment |
| C+L+S | 32 | 45 | 32.5 | 6.5 | 142 | 10 | 12 | 22 | 10 | 22 | 30 | 5 Nm |
| C+L+S | 40 | 53.5 | 38 | 6.5 | 160 | 12 | 15 | 25 | 10 | 25 | 40 | 5 Nm |
| C+L+S | 50 | 62.5 | 46.5 | 9 | 170 | 12 | 15 | 27 | 12 | 27 | 25 | 10 Nm |
| C+L+S | 63 | 73 | 56.5 | 9 | 190 | 16 | 20 | 32 | 12 | 32 | 36 | 10 Nm |
| C+L+S | 80 | 92 | 72 | 11 | 210 | 16 | 24 | 36 | 12 | 36 | 34 | 15 Nm |
| C+L+S | 100 | 108.5 | 89 | 11 | 230 | 20 | 29 | 41 | 12 | 41 | 38 | 15 Nm |
| C+L+S | 125 | 132 | 110 | 13 | 275 | 25 | 30 | 50 | 25 | 50 | 30 | 20 Nm |

Lagerbock 90° mit starrem Lager Mod. ZC

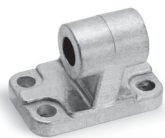

CETOP RP 107P
Werkstoff: Aluminium

Lieferumfang:
1 Lagerbock

+ Hub

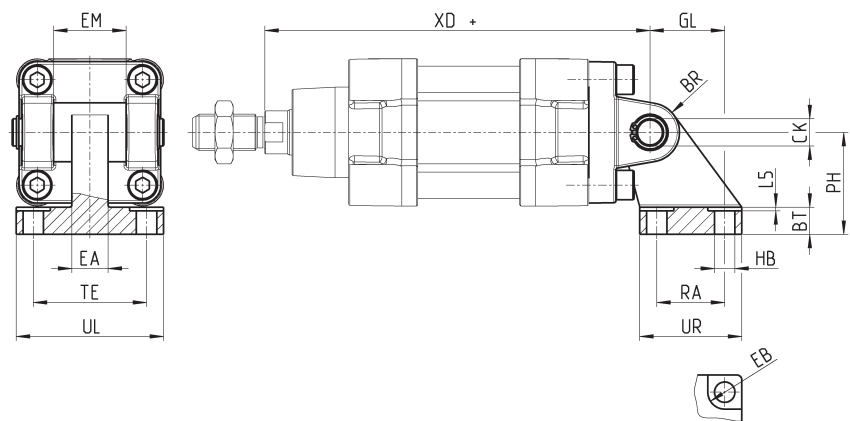

| PRODUKTÜBERSICHT | | | | | | | | | | | | | | | | |
|------------------|-----|----|----|-----|-----|----|-----|----|----|-----|----|----|----|----|----|------|
| Mod. | Ø | EB | CK | HB | XD+ | TE | UL | EA | GL | L5 | RA | EM | UR | PH | BT | BR |
| ZC-32 | 32 | 11 | 10 | 6,6 | 142 | 38 | 51 | 10 | 21 | 1,6 | 18 | 26 | 31 | 32 | 8 | 10 |
| ZC-40 | 40 | 11 | 12 | 6,6 | 160 | 41 | 54 | 15 | 24 | 1,6 | 22 | 28 | 35 | 36 | 10 | 11 |
| ZC-50 | 50 | 15 | 12 | 9 | 170 | 50 | 65 | 16 | 33 | 1,6 | 30 | 32 | 45 | 45 | 12 | 13 |
| ZC-63 | 63 | 15 | 16 | 9 | 190 | 52 | 67 | 16 | 37 | 1,6 | 35 | 40 | 50 | 50 | 14 | 15 |
| ZC-80 | 80 | 18 | 16 | 11 | 210 | 66 | 86 | 20 | 47 | 2,5 | 40 | 50 | 60 | 63 | 14 | 15 |
| ZC-100 | 100 | 18 | 20 | 11 | 230 | 76 | 96 | 20 | 55 | 2,5 | 50 | 60 | 70 | 71 | 17 | 19 |
| ZC-125 | 125 | 20 | 25 | 14 | 275 | 94 | 124 | 30 | 70 | 3,2 | 60 | 70 | 90 | 90 | 20 | 22,5 |

Lagerbock für Mittelschwenklager Mod. BF

Werkstoff: Aluminium

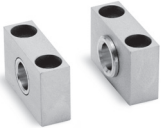

Lieferumfang:
2 Lagerböcke

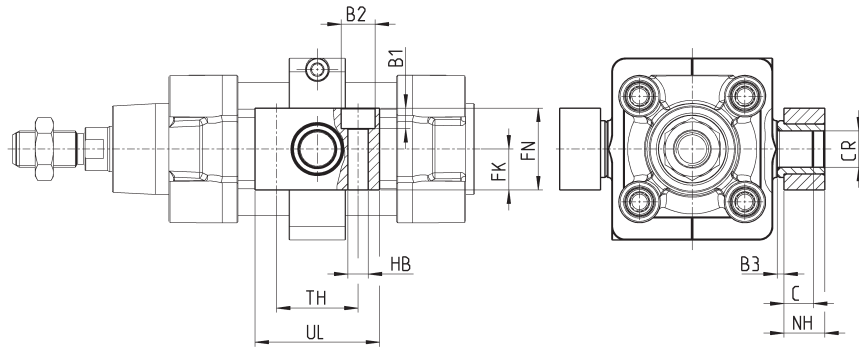

ZYLINDER ISO 15552 SERIE 63

PRODUKTÜBERSICHT

| Mod. | ∅ | CR | NH | C | B3 | TH | UL | FK | FN | B1 | B2 | HB |
|------------|-----------|----|----|------|-----|----|----|----|----|-----|----|-----|
| BF-32 | 32 | 12 | 15 | 7,5 | 3 | 32 | 46 | 15 | 30 | 6,8 | 11 | 6,6 |
| BF-40-50 | 40 - 50 | 16 | 18 | 9 | 3 | 36 | 55 | 18 | 36 | 9 | 15 | 9 |
| BF-63-80 | 63 - 80 | 20 | 20 | 10 | 3 | 42 | 65 | 20 | 40 | 11 | 18 | 11 |
| BF-100-125 | 100 - 125 | 25 | 25 | 12,5 | 3,5 | 50 | 75 | 25 | 50 | 13 | 20 | 14 |

Befestigungskit Mod. PCV

Das Befestigungskit Mod. PCV ermöglicht die Montage eines Ventils/Elektromagnetventils direkt am Zylinder. Es entsteht eine Zylinderventileinheit.



Die Gesamtlänge des gewählten Ventils (ww) sollte immer kleiner sein, als die Abmessung JJ des gewählten Zylinders. Weitere Informationen unter <http://catalogue.camozzi.com/downloads>.

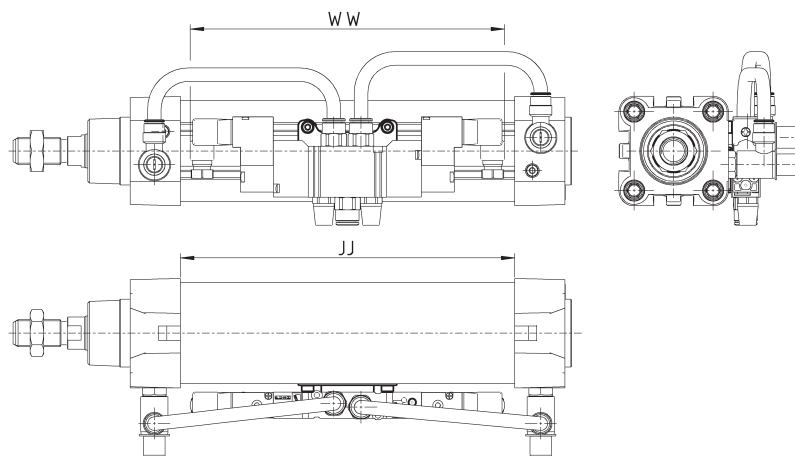

PRODUKTÜBERSICHT

| Mod. | |
|------------|--|
| PCV-62-K3 | zur Befestigung von Ventilen Serie 3 |
| PCV-62-K4 | zur Befestigung von Ventilen Serie 4 Anschluss G1/4" |
| PCV-62-KEN | zur Befestigung von Ventilen Serie EN |
| PCV-62-K8 | zur Befestigung von Ventilen Serie 4 Anchl. G1/8" + Serie 3 Anchl. G1/4" |

Lagerbolzen Mod. S



Lieferumfang:
1 Lagerbolzen (Edelstahl 1.4305)
2 Seegerringe (Stahl)

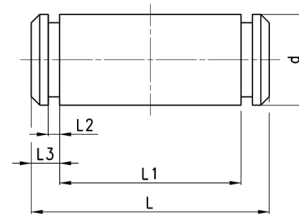

| PRODUKTÜBERSICHT | | | | | | |
|------------------|-----|----|-------|-----|-----|------|
| Mod. | ∅ | d | L | L1 | L2 | L3 |
| S-32 | 32 | 10 | 52 | 46 | 1.1 | 3 |
| S-40 | 40 | 12 | 59 | 53 | 1.1 | 3 |
| S-50 | 50 | 12 | 67 | 61 | 1.1 | 3 |
| S-63 | 63 | 16 | 77 | 71 | 1.1 | 3 |
| S-80 | 80 | 16 | 97 | 91 | 1.1 | 3 |
| S-100 | 100 | 20 | 121 | 111 | 1.3 | 5 |
| S-125 | 125 | 25 | 140.5 | 132 | 1.3 | 4.25 |

Gelenkauge Mod. GA



ISO 8139
Werkstoff: Stahl verzinkt

Lieferumfang:
1 Gelenkauge

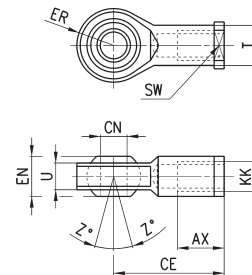

| PRODUKTÜBERSICHT | | | | | | | | | | |
|------------------|----------------------------------|------|----|----|----|-----|----------|-----------------|-----|----|
| Mod. | \varnothing CN ^(H7) | U | EN | ER | AX | CE | KK | \varnothing T | Z | SW |
| GA-32 | 10 | 10,5 | 14 | 14 | 20 | 43 | M10X1,25 | 15 | 6,5 | 17 |
| GA-40 | 12 | 12 | 16 | 16 | 22 | 50 | M12X1,25 | 17,5 | 6,5 | 19 |
| GA-50-63 | 16 | 15 | 21 | 21 | 28 | 64 | M16X1,5 | 22 | 7,5 | 22 |
| GA-80-100 | 20 | 18 | 25 | 25 | 33 | 77 | M20x1,5 | 27,5 | 7 | 30 |
| GA-41-125 | 30 | 25 | 37 | 37 | 51 | 110 | M27x2 | 40 | 7,5 | 41 |

Ausgleichskupplung Mod. GY



Werkstoff: Zinkdruckguss und Stahl verzinkt

Lieferumfang:
1 Ausgleichskupplung

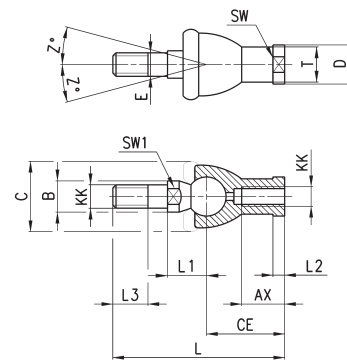

| PRODUKTÜBERSICHT | | | | | | | | | | | | | | | | |
|------------------|--------|----------|-----|----|-----|----|----|-----|------|----|-----------------|-----------------|----|-----------------|-----------------|-----|
| Mod. | ∅ | KK | L | CE | L2 | AX | SW | SW1 | L1 | L3 | \varnothing T | \varnothing D | E | \varnothing B | \varnothing C | Z |
| GY-32 | 32 | M10X1,25 | 74 | 35 | 6,5 | 18 | 17 | 11 | 19,5 | 15 | 15 | 19 | 10 | 14 | 28 | 15 |
| GY-40 | 40 | M12X1,25 | 84 | 40 | 6,5 | 20 | 19 | 17 | 21 | 17 | 17,5 | 22 | 12 | 19 | 32 | 15 |
| GY-50-63 | 50-63 | M16X1,5 | 112 | 50 | 8 | 27 | 22 | 19 | 27,5 | 23 | 22 | 27 | 16 | 22 | 40 | 11 |
| GY-80-100 | 80-100 | M20x1,5 | 133 | 63 | 10 | 38 | 30 | 24 | 31,5 | 25 | 27,5 | 34 | 20 | 27 | 45 | 7,5 |

Gabelkopf Mod. G

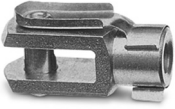

Werkstoff: Stahl verzinkt

Lieferumfang:
1 Gabelkopf

| PRODUKTÜBERSICHT | | | | | | | | | |
|------------------|-----------------|----|----|----|----|-----|------------|----|-----------------|
| Mod. | ø _{CK} | LE | CM | CL | ER | CE | KK | B | ø _{B1} |
| G-25-32 | 10 | 20 | 10 | 20 | 12 | 40 | M10 X 1,25 | 26 | 18 |
| G-40 | 12 | 24 | 12 | 24 | 14 | 48 | M12 X 1,25 | 32 | 20 |
| G-50-63 | 16 | 32 | 16 | 32 | 19 | 64 | M16 X 1,5 | 40 | 26 |
| G-80-100 | 20 | 40 | 20 | 40 | 25 | 80 | M20 X 1,5 | 48 | 34 |
| G-41-125 | 30 | 54 | 30 | 55 | 38 | 110 | M27 X 2 | 74 | 48 |

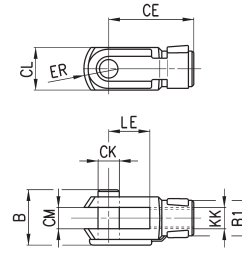

Kolbenstangenmutter Mod. U



UNI EN ISO 4035
Werkstoff: Stahl verzinkt

Lieferumfang:
1 Kolbenstangenmutter

| PRODUKTÜBERSICHT | | | |
|------------------|----------|----|----|
| Mod. | D | m | SW |
| U-25-32 | M10X1,25 | 6 | 17 |
| U-40 | M12X1,25 | 7 | 19 |
| U-50-63 | M16X1,5 | 8 | 24 |
| U-80-100 | M20x1,5 | 9 | 30 |
| U-41-125 | M27x2 | 12 | 41 |

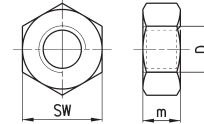

Ausgleichskupplung Mod. GK



Werkstoff: Stahl verzinkt

Lieferumfang:
1 Ausgleichskupplung

| PRODUKTÜBERSICHT | | | | | | | | | | | | | | | | | |
|------------------|--------|----------|------|----|----|-----|----------------|----------------|----|----|----|-----|-----|----|----|---|---|
| Mod. | ø | KK | L | L1 | L3 | L4 | ø _A | ø _D | H | I | SW | SW1 | SW2 | B1 | AX | Z | E |
| GK-25-32 | 25-32 | M10x1,25 | 71,5 | 35 | 20 | 7,5 | 14 | 22 | 32 | 30 | 19 | 12 | 17 | 5 | 22 | 4 | 2 |
| GK-40 | 40 | M12x1,25 | 75,5 | 35 | 24 | 7,5 | 14 | 22 | 32 | 30 | 19 | 12 | 19 | 6 | 22 | 4 | 2 |
| GK-50-63 | 50-63 | M16x1,5 | 104 | 53 | 32 | 10 | 22 | 32 | 45 | 41 | 27 | 20 | 24 | 8 | 30 | 3 | 2 |
| GK-80-100 | 80-100 | M20x1,5 | 119 | 53 | 40 | 10 | 22 | 32 | 45 | 41 | 27 | 20 | 30 | 10 | 37 | 3 | 2 |
| GK-125 | 125 | M27x2 | 147 | 60 | 54 | 10 | 32 | 57 | 70 | 65 | 54 | 24 | 41 | 12 | 48 | 4 | 2 |

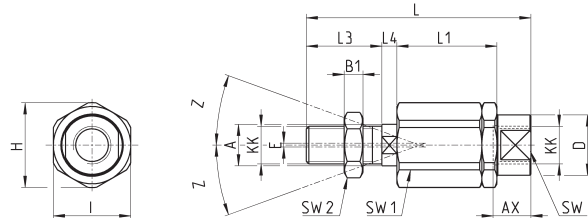

Ausgleichsflansch Mod. GKF

Werkstoff: Stahl verzinkt

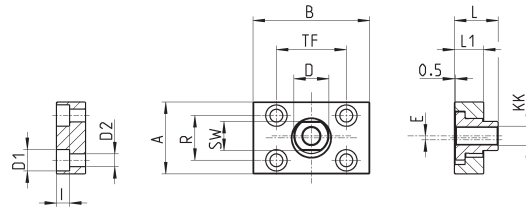

Lieferumfang:
1 Ausgleichsflansch

| PRODUKTÜBERSICHT | | | | | | | | | | | | | | |
|------------------|--------|----------|----|----|----|----|------|----|------|------|------|------|----|-----|
| Mod. | ∅ | KK | A | B | R | TF | L | L1 | I | ∅ D | ∅ D1 | ∅ D2 | SW | E |
| GKF-25-32 | 32 | M10x1,25 | 37 | 60 | 23 | 36 | 22,5 | 15 | 6,8 | 18 | 11 | 6,6 | 15 | 2 |
| GKF-40 | 40 | M12x1,25 | 56 | 60 | 38 | 42 | 22,5 | 15 | 9 | 20 | 15 | 9 | 15 | 2,5 |
| GKF-50-63 | 50-63 | M16x1,5 | 80 | 80 | 58 | 58 | 26,5 | 15 | 10,5 | 25 | 18 | 11 | 22 | 2,5 |
| GKF-80-100 | 80-100 | M20x1,5 | 90 | 90 | 65 | 65 | 32,5 | 20 | 13 | 30,5 | 20 | 14 | 27 | 2,5 |
| GKF-125 | 125 | M27x2 | 90 | 90 | 65 | 65 | 35,5 | 20 | 13 | 40 | 20 | 14 | 36 | 4 |

Demontagewerkzeug für Zylinder ∅ 80 und 100 mm (Rundrohr)

Werkstoff: Stahl gehärtet

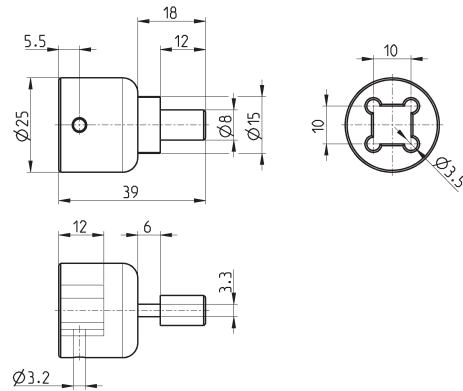
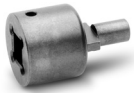

| |
|----------|
| Mod. |
| 80-62/8C |